

# Contents

---

<b>INTRODUCTION</b> .....	3
<b>INSTALLATION OF THE SYSTEM</b> .....	4
2.1 Installation of the activated detection loop.....	4
2.2 Installation of the transponder.....	9

## Appendices

APPENDIX A - USEFUL TOOLS/PARTS/EQUIPMENT.....	11
APPENDIX B - TECHNICAL SPECIFICATIONS.....	12
APPENDIX C - CE AND FCC REGULATIONS.....	13
GUARANTEES & WARRANTIES.....	14

## Figures

Figure 1.1 System overview.....	3
Figure 2.1 Detection loop installation overview.....	4
Figure 2.2 Solder the loop wire end.....	6
Figure 2.4 Transponder placement.....	9

# **Contact Information**

---

## **AMB i.t. Europe**

Amsterdam  
The Netherlands  
Tel: +31 23 529 1893  
E-mail:  
support@amb-europe.com

## **AMB i.t. America**

Atlanta  
USA  
Tel: +1 678 816 4000  
E-mail:  
support@amb-us.com

## **AMB i.t. Asia (Japan Branch)**

Tokyo  
Japan  
Tel: +81 3 5275 4600  
Email:  
support@amb-japan.com

## **AMB i.t. Asia (Australian Branch)**

Sydney  
Australia  
Tel: +61 2 9546 2606  
Email:  
support@amb-australia.com

**www.amb-it.com**



## **All rights reserved**

Copyright 2004-2008 AMB i.t. BV

This publication has been written with great care. However, the manufacturer cannot be held responsible, either for any errors occurring in this publication or for their consequences.

The sale of products, services or goods governed under this publication are covered by AMB i.t.'s standard Terms and Conditions of Sales and this product Manual is provided solely for informational purposes. This publication is to be used for the standard model of the product of the type given on the cover page.

AMB i.t.

Manual:TranX140/Rev.07/08

# 1: Introduction

The TranX140 system is specifically designed for timing and scoring for entertainment karting. The signal sent by the TranX140 transponder is picked up by the active detection loop that is installed in the track. The transponder itself is installed permanently on a kart. The detection loop is connected to the ecoder. The decoder timestamps the received transponder signals and sends this data to a connected computer.

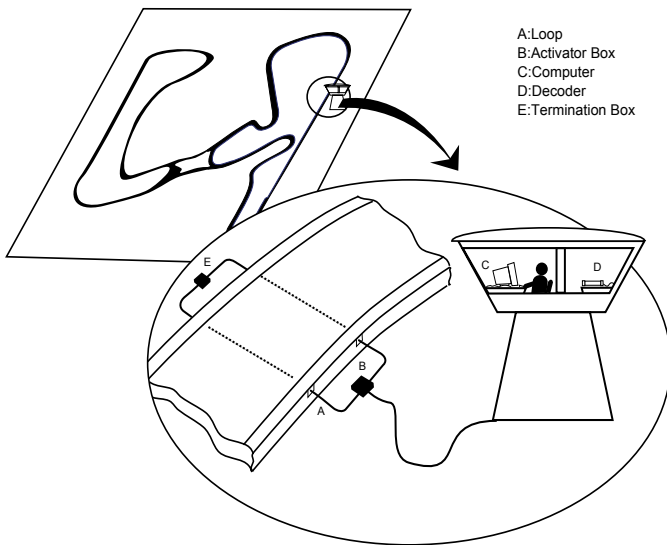

**Figure 1.1 System overview**

## 2: Installation of the system

To install the TranX140 system, one needs to install an activated detection loop, connect the decoder and mount the TranX140 transponders. For optimal results, please abide by the instructions as described in the following paragraphs carefully.

### 2.1 Installation of the activated detection loop

All wiring of the activated detection loop must be installed according to the drawing below in order to avoid a serious degradation in the performance of the system.

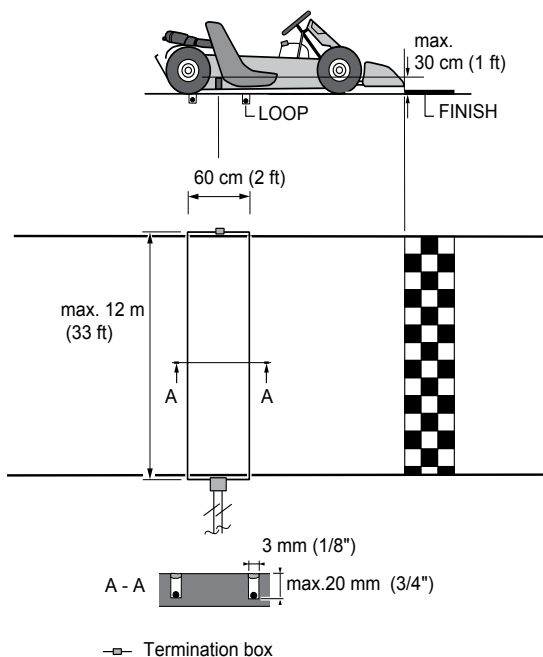

**Figure 2.1 Detection loop installation overview**

## **Positioning the activated detection loop**

- a) The activated detection loop must be positioned in such a way that the transponder is above the center of the loop when the front of the kart is above the finish line. Make sure karts cannot pass outside the activated detection loop, extend it outside the track if necessary.
- b) The activated detection loop can be used for a track width of a maximum 12 m (36 ft).
- c) Cut the slots in the track a maximum of 2 cm (3/4 in) deep and 60 cm (2 ft) apart.

## **Installation of the detection loop wires and cabling**

- a) Make sure the slots are clean and dry. This will ensure a perfect seal when the silicon is applied after installation of the wiring. Put the wires of the detection loop in the slots and cut the excess length of the detection loop wires.
- b) When all wires are installed, put the heat shrink sleeve over a detection loop wire end. Then solder the loop wire end to the short wire end of the activator box. When soldering the wires together, the solder should flow through the entire connection and not only around it. Now put the shrinkage sleeve over soldered connection and hold it over a heat source to shrink the sleeve (see figure 2.2). Repeat this procedure for the second wire end of the detection loop.
- c) Fill the slot with silicone. Make sure not to overfill the slots and that the silicone is fully under the surface of the track, otherwise tires may pull out the silicone. If any silicone spills out of the slot, remove the excess silicone by scraping the top with a small piece of cardboard. This also ensures that the silicone is pressed into the slot and into the sides of the slot to ensure a perfect seal.

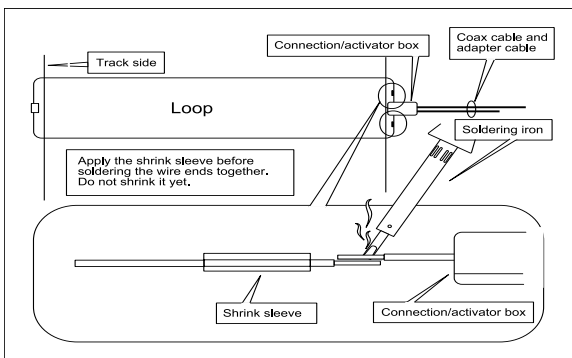

**Figure 2.2 Solder the loop wire end**

---

## LEARNED BY EXPERIENCE

If you wish, you may pad the slots with backing rod or nylon cord before sealing the slot with silicone. This helps to prevent the excessive use of silicone and is also useful when pulling out the silicone if the detection loop has to be replaced.

### Silicone

There are a wide variety of silicone types available in hardware stores; it is important that the right type is used. Silicone that can withstand different temperatures as well as both dry and wet conditions since weather situations can vary should be used. If you are unsure, check the specifications of the silicone. The following types of silicone have been shown to yield lasting results and are recommended by AMB:

- Dow Corning 890SL is a self-leveling silicone kit. It is applied as a liquid and fills the slot completely.
  - Purflex is a polyurethane-based silicone that retains its elasticity under a wide range of temperatures.
-

- d) The activated detection loop is sensitive to interference, sometimes emitted by nearby cables. When possible, keep other cables 5 m (15 ft) away. Also make sure karts on other parts of the track will not get closer than 5 m (15 ft) to the detection loop, to avoid false inputs.
- e) Finish the installation of the activated detection loop by powering it. The activator will tune itself when the power is supplied. To tune your activator, please follow this steps:
  - Connect all cables (loop wires, coax)
  - Switch on the enclosed power supply (13,6 VDC)
  - Green LED will start blinking and you will hear the activator ticking.
  - When the ticking stops the activator is tuned
  - The green LED must indicate green continuously.

When the activator is tuned, the green LED must indicate solid green. When the green LED is blinking, the activator is not tuned correctly. This can be caused by these problems:

**- The power supply was connected first:**

Make sure that you first connect the loop with the activator before you connect the power supply.

**- No loop wires are connected:**

Make sure you connect all cables including the loop wires.

**- The loop wires are broken:**

Replace the broken loop wire

**- The activator is not working properly:**

First check the power supply, when your activator is still not working, please contact AMB

## Testing the active detection loop installation

Once the loop has been installed, it should be tested to ensure that it is functioning correctly. We also recommend repeating the same procedure at the start of each race event. You can determine if your loop is functioning correctly by doing the following tests:

- a) Connect the activated detection loop to the decoder and computer running AMB i.t. timing software (also see the separate decoder manual).  
Check the background noise, which is updated every five seconds in the AMB i.t. timing software. The background noise level should be between 0 and 40 points. A higher value may indicate interference by other electrical equipment in the area or a bad loop installation.  
Try switching off the activator and check for a change in the background noise. A higher value may also indicate interference by other electrical equipment in the area.  
Try switching off any suspected equipment or removing nearby objects and check for improvements. Especially at night, short-wave radios may cause an increased background noise.

---

### LEARNED BY EXPERIENCE

A metal timekeeping building can cause the system to pick up more interference via the coax cabling, which can result in an increased background noise.

---

- b) Check the signal strengths of the transponders as they are picked up by the system during a reality test (also see paragraph 2.2 Installation of the transponder). A good loop will yield consistent transponder signal strengths of at least 80 points with a hit rate of at least 20 points. The hit rate



may vary (slower passings yield higher hit counts), but the signal strength should be consistent (approximately 10 points variance) for the same kart.

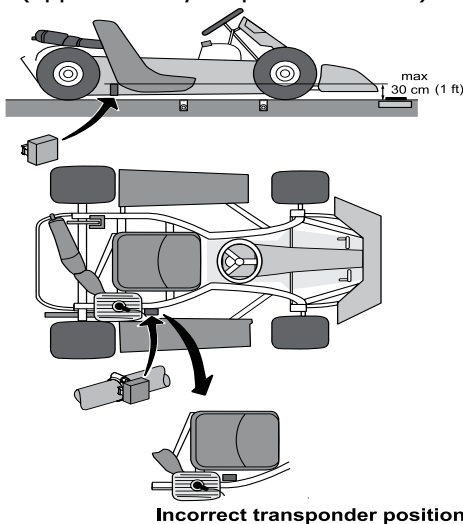

Figure 2.4 Transponder placement

## 2.2 Installation of the transponder

The TranX140 Transponder is equipped with a permanent battery and therefore does not need to be recharged. This assures a reliable and maintenance-free operation. When the transponder passes the detection loop, it is automatically activated and only uses a spark of energy during the actual loop passing before automatically switching off again.

### Positioning the transponder

The position of the transponder must be identical on all karts competing in the race. Fix the transponder, a maximum of 30 cm (1 ft), above the track. Make sure that the transponder has a clear opening to the track with no metal or carbon fiber beneath it.

Fix the transponder on the kart by using a hose clamp. The transponder can be oriented towards the front, back or the side of the kart. Mount the transponder horizontally, with the arrows on the transponder to the track. Mount the TranX140 transponder on the outside of the frame. When mounted inside the frame, the activating signal may prove difficult to activate the transponder. As a result, it is possible that a transponder will not register even when mounted a maximum of 30 cm (1ft) above the track.

## **WARNING**

A detached transponder can be very dangerous! Make sure the transponder cannot get detached.

## **Appendix A: Useful tool/parts/ equipment**

---

### Useful Tools

- Resistance meter (Range at least: 1 Ohm - 1 Mega Ohm)
- Wire cutter / stripper
- BNC Crimper
- (Butane) Soldering gun
- Blade knife
- Coax stripper
- Screw driver (normal and Phillips)

### Useful Spare Parts

- BNC couplers (3 pieces)
- Thick BNC connectors (5 pieces)
- Thin BNC connectors (5 pieces)
- Shrink sleeves
- Active spare loop (for tracks up to 12 m (36 ft) wide)
- Electrical tape

### Additional Tool for new loop installations

- Chalk line
- Caulk gun

Please contact AMB i.t. if you would like to receive detailed specifications on any of the above items. You can find our contact details on page 2 of this manual.

## **Appendix B: Technical Specifications**

### **TranX140 Transponder**

Numbers available	: unlimited
Dimensions	: 40x40x34 mm (approx. 1.5x1.5x0.5 in)
Weight	: 55 g
Housing	: Water- and shockproof
Max. speed	: 120 km/h (75 mph)
Timing Resolution	: 0,01 sec
Temperature range	: 0 - 50 °C (32 - 122 °F)
Operating time	: min. 1.000.000 loop passings
Signal transfer	: magnetic induction
Transponder position	: max. height 30 cm (1 ft)

### **AMB Active Detection Loop**

Track width	: max. 12 m (36 ft)
Loop width	: 60 cm (2 ft)
Coax to decoder	: max. 100 m (330 ft) double shielded 75 ohm
Power supply	: 13.6 VDC / 1,1 A via 115 or 230 VAC adapter
Power cable (18 AWG)	: max. 100 m (330 ft) twin wire 2x0.75 mm <sup>2</sup>
Loop wire (18 AWG)	: d=3 mm (1/8 in), tinned copper, 0.75 mm <sup>2</sup>

Specifications are subject to change without notice.

## Appendix C: CE and FCC Regulations



### **CE information:**

This device complies with the EMC directive 89/336/EEC. A copy of the declaration of conformity can be obtained at:

AMB i.t. BV  
Zuiderhoutlaan 4  
2012 PJ Haarlem  
The Netherlands



### **FCC information:**

This equipment complies with part 15 of the FCC rules. Operation is subject to the following two conditions: (1) This equipment may not cause harmful interference, and (2) this equipment must accept any interference received, including interference that may cause undesired operation.

# **Guarantees & Warranties**

---

AMB warrants that, for a period of three (3) years from the date of shipping the decoders and the AMBmx, AMBrc DP, TranX160 DP, TranX160, TranX260 DP, TranX260, TranX Pro transponders covered by this warranty with defects, as determined solely by AMB, caused by faulty materials, workmanship or design will be repaired or replaced, unless such defects were the result of any of the following: shipping; improper installation, maintenance or use; abnormal conditions of operation; attempted modification or repair by the customer or any third party; use of the goods in combination with other items; or an act of God. If repair or replacement of the goods is not possible or economical for AMB, AMB may, at its option, refund the purchase price of the goods or deliver replacement goods at its sole discretion. AMB's liability shall be strictly limited to replacing, repairing or issuing credits at its option.

AMB warrants that, for a period of two (2) years from the date of shipping the ProChip, TranX140 and the AMBrc transponders covered by this warranty with defects, as determined solely by AMB, caused by faulty materials, workmanship or design will be repaired or replaced, unless such defects were the result of any of the following: shipping; improper installation, maintenance or use; abnormal conditions of operation; attempted modification or repair by the customer or any third party; use of the goods in combination with other items; or an act of God. If repair or replacement of the goods is not possible or economical for AMB, AMB may, at its option, refund the purchase price of the goods or deliver replacement goods at its sole discretion. AMB's liability shall be strictly limited to replacing, repairing or issuing credits at its option.

AMB warrants that, for a period of one (1) year from the date of shipping the TnetX Display Kit covered by this warranty with defects, as determined solely by AMB, caused by faulty materials, workmanship or design will be repaired or replaced, unless such defects were the result of any of the following: shipping; improper installation, maintenance or use; abnormal conditions of operation; attempted modification or repair by the customer or any third party; use of the goods in combination with other items; or an act of God. If repair or replacement of the goods is not possible or economical for AMB, AMB may, at its option, refund the purchase price of the goods or deliver replacement goods at its sole discretion. AMB's liability shall be strictly limited to replacing, repairing or issuing credits at its option.

AMB warrants that, for a period of one (1) year from the date of shipping, all other goods covered by this warranty with defects, as determined solely by AMB, caused by faulty materials, workmanship or design will be repaired or replaced, unless such defects were the result of any of the following: shipping; improper installation, maintenance or use; abnormal conditions of operation; attempted modification or repair by the customer or any third party; use of the goods in combination with other items; or an act of God. If repair or replacement of the goods is not possible or economical for AMB, AMB may, at its option, refund the purchase price of the goods or deliver replacement goods at its sole discretion. AMB's liability shall be strictly limited to replacing, repairing or issuing credits at its option.

If the requirements set forth above and described under Remedies and Damages are not complied with, our warranty/guarantee shall not apply and we shall be discharged from all liability arising from the supply of defective goods.

EXCEPT AS EXPRESSLY PROVIDED IN THIS SECTION, AMB MAKES NO REPRESENTATIONS OR WARRANTIES OF ANY KIND, NATURE OR DESCRIPTION, EXPRESS OR IMPLIED, INCLUDING WITHOUT LIMITATION, ANY WARRANTY OR MERCHANTABILITY, FITNESS OF THE GOODS FOR ANY PARTICULAR PURPOSE, OR NONINFRINGEMENT, AND AMB HEREBY DISCLAIMS THE SAME.

### **Remedies and Damages**

1. AMB shall not incur any liability under the above warranty unless:
  - i) AMB is promptly notified in writing upon discovery by the customer that such goods do not conform to the warranty, and the appropriate invoice number and date of purchase information is supplied;
  - ii) The alleged defective goods are returned to AMB carriage pre-paid;
  - iii) Examination by AMB of goods shall confirm that the alleged defect exists and has not been caused by unauthorized use (including, without limitation, the use of an AMB decoder with non-AMB hardware) misuse, neglect, method of storage, faulty installation, handling, or by alteration or accident; and
  - iv) With respect to AMB decoders, customer has upgraded the firmware in its decoder within one month after AMB has offered to provide customer with such upgraded firmware.
2. The customer acknowledges that the goods may include certain firmware imbedded therein. AMB hereby grants a license to customer to use the imbedded firmware in an AMB decoder, but only to the extent the decoder is used in connection with AMB hardware. AMB shall have the right to terminate the license immediately upon written notice to customer in case AMB has a reasonable belief that customer at any time has used the AMB decoder in connection with non-AMB hardware. Further, customer may not copy, compile, reverse compile, disassemble, translate, analyze, reverse engineer or attempt to reverse engineer the firmware, except as permitted by applicable law.
3. In addition, customer grants AMB the option to repurchase any AMB decoder if AMB has a reasonable belief that customer has used the AMB decoder in connection with non-AMB hardware. The repurchase price shall be the fair market value on the date AMB provides notice to customer that it intends to repurchase the decoder.

The above mentioned warranty/guarantee is irrespective of any rights granted to the buyer of AMB equipment manufactured or sold by AMB i.t. based on the laws of the Netherlands. Any correspondence regarding the above mentioned guarantee must be addressed to AMB i.t.:

AMB i.t.  
Zuiderhoutlaan 4  
2012 PJ HAARLEM  
THE NETHERLANDS  
E-mail: support@amb-europe.com  
Fax: +31 23 529 0156